

# Product Datasheet

description:	R WH 0,5L ws29 47g DIN60 240/KRT 4KRT/CP2HT UN	year:	2004
product group:	Square Chemical Bottle	last revision:	2013-05-28
Mauser product no.:	DE03006610	print date:	2021-11-11
customer item no.:		page:	1/2

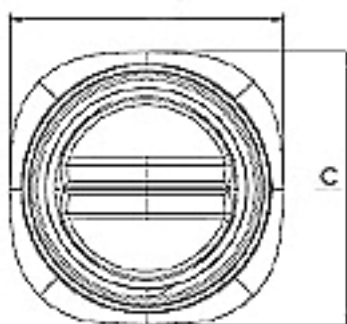
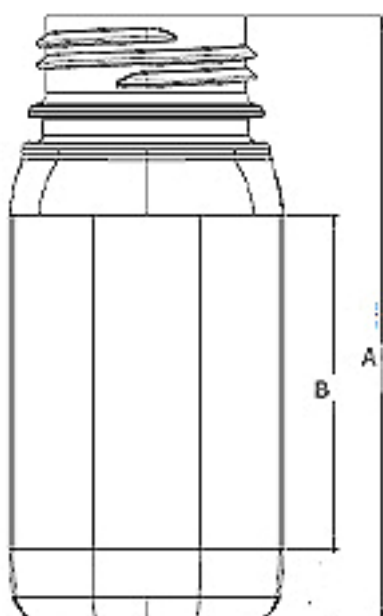

Drawing only exemplary

## DIMENSIONS

A:	167.00 mm
B:	92.00 mm
C:	75.00 mm
D:	75.00 mm
E:	./.

## TOLERANCE

A:	+/- 2.2 mm
B:	./.
C:	+/- 1.5 mm
D:	+/- 1.5 mm
E:	./.

## WEIGHT

weight (body piw):	0.047 kg
--------------------	----------

## MATERIAL

Material:	HDPE
-----------	------

## VOLUME

nominal volume [l]:	0.5 L
brimful volume:	./.

## DRAWING NUMBER

Mauser drawing no.:	42491b
---------------------	--------

### Mauser-Werke GmbH

Wilhelm-Weber-Stra 6 D-21079 Hamburg Germany  
 Phone: +49 (0) 4076733238 Fax: +49 (0) 4076733267  
 info@mauserpackaging.com  
 http://www.mauserpackaging.com

# Product Datasheet

description:	R WH 0,5L ws29 47g DIN60 240/KRT 4KRT/CP2HT UN	year:	2004
product group:	Square Chemical Bottle	last revision:	2013-05-28
Mauser product no.:	DE03006610	print date:	2021-11-11
		page:	2/2

## LABELING

Embossing/Labeling/Printing:	./.	customer spec no.:	
label:			

## MODEL / COMPONENTS / ACCESSORIES

Basic Colors:	white	colour type:	FK weiss
Quality and/or Functionality:	./.	Narrow Neck Typ:	./.
Wide Neck Typ:	DIN 60 W Orig.	Wide Neck Typ 2:	./.
Number of Layers/View Stripe:	Monolayer	Screw Cap/Dust Cap:	./.
FoodProtect:	no		

## SHIPPING UNIT

Palletizing:	Strechfoil & PE Film Cover	Pallettyp:	CP2 (800x1200mm)
pieces per pallet:	960	outer packaging:	4 card boxes with PE bag per pallet
number of Interlayers:	./.	type of Interlayer:	./.

## STANDARD FILLING PRODUCTS

Approval Category:	./.	Approval Density:	./.
Approval Pressure:	0 (solids)		

	max. vapour pressure at 50C	max. vapour pressure at 55C	density PG I	density PG II	density PG III
solid:	./.	./.	2.5	2.5	2.5
water:	./.	./.	./.	./.	./.
acetic acid:	./.	./.	./.	./.	./.
wetting solution:	./.	./.	./.	./.	./.
white spirit:	./.	./.	./.	./.	./.
n-butyl acetate:	./.	./.	./.	./.	./.
nitric acid 55%:	./.	./.	./.	./.	./.

approval: UN 3H1/X0,9/S/./D/BAM 12359-M3